



EMC TEST REPORT

For

Otennlux lighting technology co.,ltd

LED signal light

Test Model: OLL7-2000-1

Additional Models : please refer to model list

Prepared for : Otennlux lighting technology co.,ltd
Address : 301, workshop 2, No.4, Xingda Road, Pingshan 1st Village,
Shibistreet, Panyu District, Guangzhou City, Guangdong Province



Prepared by : Shenzhen Southern LCS Compliance Testing Laboratory Ltd.
Address : 101-201, No.39 Building, Xialang Industrial Zone, Heshuikou
Community, Matian Street, Guangming District, Shenzhen, China

Tel : (+86)755-29871520
Fax : (+86)755-29871521
Web : www.LCS-cert.com
Mail : webmaster@LCS-cert.com

Date of receipt of test sample : January 8, 2024
Number of tested samples : 1
Serial number : Prototype
Date of Test : January 8, 2024 - January 10, 2024
Date of Report : January 10, 2024



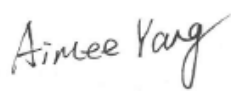

EMC TEST REPORT EN IEC 55015:2019+A11:2020 Emission - Electrical lighting and similar equipment EN IEC 61547:2023 Equipment for general lighting purposes - EMC immunity requirements		
Report Number : LCSB01064024E Date of Issue..... : January 10, 2024		
Testing Laboratory Name : Shenzhen Southern LCS Compliance Testing Laboratory Ltd. Address : 101-201, No.39 Building,Xialang Industrial Zone, Heshuikou Community, Matian Street,Guangming District, Shenzhen, China.		
Testing Procedure : Full application of Harmonised standards <input checked="" type="checkbox"/> Partial application of Harmonised standards <input type="checkbox"/> Other standard testing method <input type="checkbox"/>		
Applicant's Name : Otennlux lighting technology co.,ltd Address : 301, workshop 2, No.4, Xingda Road, Pingshan 1st Village, Shibistreet, Panyu District, Guangzhou City, Guangdong Province		
Test Specification: Standard : EN IEC 55015:2019+A11:2020 EN IEC 61547:2023		
Test Report Form No. : SLCSEMC-2.3 TRF Originator : Shenzhen Southern LCS Compliance Testing Laboratory Ltd. Master TRF : Dated 2016-08		
Shenzhen Southern LCS Compliance Testing Laboratory Ltd. All rights reserved. This publication may be reproduced in whole or in part for non-commercial purposes as long as the Shenzhen Southern LCS Compliance Testing Laboratory Ltd. is acknowledged as copyright owner and source of the material. Shenzhen Southern LCS Compliance Testing Laboratory Ltd. takes no responsibility for and will not assume liability for damages resulting from the reader's interpretation of the reproduced material due to its placement and context.		
Equipment Under Test. : LED signal light Trademark : OTENNLUX Test Model/Type : OLL7-2000-1 Rating : See model list Results : PASS		
Compiled by:  Ella Huang / Engineer	Supervised by:  Aimee Yang / Technique Director	Approved by:  Dm Gu / Manager





EMC - TEST REPORT

Test Report No.....: LCSB01064024E

Applicant.....:	Otennlux lighting technology co.,ltd
Address.....:	301, workshop 2, No.4, Xingda Road, Pingshan 1st Village, Shibistreet, Panyu District, Guangzhou City, Guangdong Province
Telephone.....:	/
Fax.....:	/

Manufacturer	Zhongshan Erdu Lighting Technology Co., Ltd
Address.....:	6 th Floor, Building B, No.3 Lelin Street, Guzhen, Zhongshan, Guangdong
Telephone.....:	/
Fax.....:	/

Factory	Zhongshan Erdu Lighting Technology Co., Ltd
Address.....:	6 th Floor, Building B, No.3 Lelin Street, Guzhen, Zhongshan, Guangdong
Telephone.....:	/
Fax.....:	/

The applicant and manufacturer information, product name, model, trademark and other information in this report are all provided by the applicant, and this laboratory is not responsible for verifying its authenticity.

The test report merely corresponds to the test sample.
It is not permitted to copy extracts of these test result without the written permission of the test laboratory.





ENVIRONMENTAL CONDITIONS

The climatic conditions during the test are within the limits specified by the manufacturer for the operation of the EUT and the test equipment. the climatic conditions during the test were in the following Limits:

Ambient temperature	15°C - 30°C
Relative Humidity air	30% - 60%
Atmospheric pressure	86 kPa - 106 kPa

Climate values will be recorded and recorded separately if specifically required in the base standard or application product/product series standard.

POSSIBLE TEST CASE VERDICTS

Test cases does not apply to test object	N/A
Test object does meet requirement	P(Pass) / PASS
Test object does not meet requirement	F(Fail) / FAIL
Not measured	N/M

DEFINITION OF SYMBOLS USED IN THIS TEST REPORT

<input checked="" type="checkbox"/> Indicate that the conditions, standards or equipment listed is applicable to this report / test / EUT.
<input type="checkbox"/> Indicate that the conditions, standards or equipment listed is not applicable to this report / test / EUT.

REVISION HISTORY

Revision	Issue Date	Revision Content	Revised by
000	January 10, 2024	Initial Issue	-

Remark:
000) : “---”





TABLE OF CONTENTS

- 1. GENERAL INFORMATION..... 6**
 - 1.1. General Description of The Item(s)..... 6
 - 1.2. Operating Mode(s) Used of Tests..... 7
 - 1.3. Support / Auxiliary Equipment for The EUT 7
 - 1.4. Description of Test Facility..... 7
- 2. STATEMENT OF THE MEASUREMENT UNCERTAINTY 8**
- 3. MEASURING DEVICES AND TEST EQUIPMENT 9**
- 4. VERDICT SUMMARY SECTION 11**
 - 4.1. Standard(s)..... 11
 - 4.2. Overview of Results..... 12
- 5. EMISSION TESTS 13**
 - 5.1. Conducted Disturbance..... 13
 - 5.2. Radiated Disturbance (9KHz - 30MHz)..... 15
 - 5.3. Radiated Disturbance (30MHz - 1GHz) 16
- 6. IMMUNITY TESTS 17**
 - 6.1. Performance Criteria 17
 - 6.2. Electrostatic Discharge 18
 - 6.3. Radio-Frequency Electromagnetic Fields..... 19
 - 6.4. Electrical Fast Transient / Burst 20
 - 6.5. Injected Currents (Radio-Frequency Common Mode) 21
- ANNEX A - TEST RESULTS 22**
- ANNEX B - TEST PHOTOS 31**
- ANNEX C - EXTERNAL AND INTERNAL PHOTOS OF THE EUT 34**





1. GENERAL INFORMATION

1.1. GENERAL DESCRIPTION OF THE ITEM(S)

Equipment Under Test	LED signal light
Test Model/Type	OLL7-2000-1
Additional Models/Type	See model list
Description of Model difference	See model list
Rating	See model list

Model List:

Declared by applicant as follows:

- All models use the same circuit and PCB layout.
- All models have similar appearance and structure except model name and color.
- This report after information review and verification, the model(s) "OLL7-2000-1" were chosen as the representative model to perform all the tests.

Model	Rating	Remark
OLL-1-260-X, OLL-1-812-X, OLL-1-854-X, OLL-1-1654-X, OLL1-1-300-X, OLL1-2-500-X, OLL1-3-800-X, OLL1-4-1200-X, OLL2-300-Y, OLL2-346-Y, OLL2-400-Y, OLL2-454-Y, OLL2-500-Y, OLL2-600-Y, OLL2-800-Y, OLL2-1000-Y, OLL2-1200-Y, OLL2-1500-Y, OLL2-1700-Y, OLL2-2000-Y, OLL3-238-X, OLL3-300-X, OLL3-346-X, OLL3-400-X, OLL3-454-X, OLL3-500-X, OLL3-600-X, OLL3-670-X, OLL3-778-X, OLL3-800X, OLL3-1000-X, OLL3-1200-X, OLL3-1426-X, OLL3-1500-X, OLL3-1700-X, OLL3-2000-X, OLL4-1-X, OLL4-2-X, OLL4-3-X, OLL4-4-X, OLL5-195-X, OLL5-335-X, OLL5-475-X, OLL5-615-X, OLL5-895-X, OLL5-1175-X, OLL6-1-X, OLL6-2-X, OLL6-3-X, OLL6-4-X, OLL6-5-X, OLL6-6-X, OLL7-238-X, OLL7-300-X, OLL7-346-X, OLL7-400-X, OLL7-454-X, OLL7-500-X, OLL7-600-X, OLL7-670-X, OLL7-778-X, OLL7-800X, OLL7-1000-X, OLL7-1200-X, OLL7-1426-X, OLL7-1500-X, OLL7-1700-X, OLL7-2000-X, OLL8-300-Y, OLL8-346-Y, OLL8-400-Y, OLL8-454-Y, OLL8-500-Y, OLL8-600-Y, OLL8-800-Y, OLL8-1000-Y, OLL8-1200-Y, OLL8-1500-Y, OLL8-1700-Y, OLL8-2000-Y, OLL9-195-X, OLL9-335-X, OLL9-475-X, OLL9-615-X, OLL9-895-X, OLL9-1175-X, OLWS-346-RYG, OLWS-625-RYG, OLWS-910-RYG, OLWS-1190RYG, OLWS-346-RYGW, OLWS-625-RYGW, OLWS-910-RYGW, OLWS-1190RYGW	DC24V, 12W	X (P: NPN; N : NPN) Y(1: Red; 2: Yellow; 3: Green; 4: Red & Green; 5: Yellow & Green)
Test model: OLL7-2000-1		



Shenzhen Southern LCS Compliance Testing Laboratory Ltd.

101-201, No. 39 Building, Xialang Industrial Zone, Heshuikou Community, Matian Street, Guangming District, Shenzhen, China.

Tel: +(86) 0755-82591330 | E-mail: webmaster@lcs-cert.com | Web: www.lcs-cert.com.

Scan code to check authenticity.



1.2. OPERATING MODE(S) USED OF TESTS

During the tests, the following operating mode(s) has(have) been used.

Operating Mode	Operating Mode description	Used for testing	
		Emission	Immunity
1	Lighting on mode	<input checked="" type="checkbox"/>	<input checked="" type="checkbox"/>
2	Maximum light	<input type="checkbox"/>	<input type="checkbox"/>
3	Minimum light	<input type="checkbox"/>	<input type="checkbox"/>
4	Charging+Lighting	<input type="checkbox"/>	<input type="checkbox"/>

1.3. SUPPORT / AUXILIARY EQUIPMENT FOR THE EUT

EUT has been tested using the following auxiliary equipment :

Auxeq	Model/Type	Manufacturer	Supplied by
--			

1.4. DESCRIPTION OF TEST FACILITY

Test Location	Shenzhen Southern LCS Compliance Testing Laboratory Ltd. 101-201, No.39 Building,Xialang Industrial Zone, Heshuikou Community, Matian Street, Guangming District, Shenzhen, China. CNAS Registration Number is L10160.
Date of receipt of test item	January 8, 2024
Date(s) of performance of test	January 8, 2024 - January 10, 2024





2. STATEMENT OF THE MEASUREMENT UNCERTAINTY

The data and results referenced in this document are true and accurate. The reader is cautioned that there may be errors within the calibration limits of the equipment and facilities. The measurement uncertainty was calculated for all measurements listed in this test report according to CISPR 16 - 4 "Specification for radio disturbance and immunity measuring apparatus and methods - Part 4: Uncertainty in EMC Measurements" and is documented in the LCS quality system according to DIN EN ISO/IEC 17025. Furthermore, component and process variability of devices similar to that tested may result in additional deviation. The manufacturer has the sole responsibility of continued compliance of the device.

Measurement	Uncertainty (U_{lab})
Conducted disturbance (9kHz - 30MHz)	± 2.80 dB
Magnetic field disturbance (9kHz - 30MHz)	± 3.46 dB
Radiated disturbance (30MHz - 200MHz)	± 4.66 dB
Radiated disturbance (200MHz - 1GHz)	± 4.64 dB

Supplementary information:

The reported expanded uncertainty of measurement is stated as the standard uncertainty of measurement multiplied by the coverage factor of $k=2$, which for a normal distribution corresponds to a coverage probability of approximately 95%.





3. MEASURING DEVICES AND TEST EQUIPMENT

CONDUCTED DISTURBANCE						
Item	Test equipment	Manufacturer	Model No.	Serial No.	Cal Date	Due Date
1	No. 1 shielded Room	CHENGYU	843	/	2023-04-26	2026-04-25
2	EMI Test Receiver	R&S	ESCI	101142	2023-04-26	2024-04-25
3	10dB Attenuator	SCHWARZBECK	VTSD9561-F	9561-F159	2023-04-26	2024-04-25
4	Artificial Mains Network	SCHWARZBECK	NSLK 8163	00043	2023-09-04	2024-09-03
5	Impedance Stabilization Network	SCHWARZBECK	NTFM 8158	NTFM8158#120	2023-04-26	2024-04-25
6	Voltage Probe	SCHWARZBECK	KT 9420	9420401	2023-04-26	2024-04-25
7	EMI Test Software	EZ	EZ_EMG	N/A	/	/

RADIATED DISTURBANCE (9KHz - 30MHz)						
Item	Test equipment	Manufacturer	Model No.	Serial No.	Cal Date	Due Date
1	No. 1 shielded Room	CHENGYU	843	/	2023-04-26	2026-04-25
2	EMI Test Receiver	R&S	ESCI	101142	2023-04-26	2024-04-25
3	10dB Attenuator	SCHWARZBECK	VTSD9561-F	9561-F159	2023-04-26	2024-04-25
4	Triple-loop Antenna	EVERFINE	LLA-2	11050003	2023-04-26	2024-04-25
5	EMI Test Software	EZ	EZ_EMG	N/A	/	/

RADIATED DISTURBANCE (above 30MHz)						
Item	Test equipment	Manufacturer	Model No.	Serial No.	Cal Date	Due Date
1	3m Semi Anechoic Chamber	SIDT FRANKONIA	SAC-3M	03CH03-HY	2021-05-28	2024-05-29
2	EMI Test Receiver	R&S	ESCI3	101010	2023-04-26	2024-04-25
3	Log-periodic Antenna	SCHWARZBECK	VULB9163	5094	2022-05-08	2025-05-07
4	Coupling Decoupling Network	SCHWARZBECK	CDNE M2	00251	2023-04-26	2024-04-25
5	Coupling Decoupling Network	SCHWARZBECK	CDNE M3	00248	2023-04-26	2024-04-25
6	EMI Test Software	EZ	EZ_EMG	N/A	/	/
7	Controller system	SKET	SKC1000	N/A	/	/

ELECTROSTATIC DISCHARGE						
Item	Test equipment	Manufacturer	Model No.	Serial No.	Cal Date	Due Date
1	ESD Simulator	TESEQ	NSG 437	1615	2023-03-20	2024-03-19

ELECTRICAL FAST TRANSIENT / BURST						
Item	Test equipment	Manufacturer	Model No.	Serial No.	Cal Date	Due Date
1	Electrical Fast Transient Generator	HTEC	HEFT51	162201	2023-04-26	2024-04-25
2	EFT Coupling Clamp	HTEC	H3C	163701	2023-04-26	2024-04-25

INJECTED CURRENTS (RADIO-FREQUENCY COMMON MODE)						
Item	Test equipment	Manufacturer	Model No.	Serial No.	Cal Date	Due Date
1	No. 2 shielded room	CHENGYU	743	/	2023-04-26	2026-04-25



Shenzhen Southern LCS Compliance Testing Laboratory Ltd.

101-201, No. 39 Building, Xialang Industrial Zone, Heshuikou Community, Matian Street, Guangming District, Shenzhen, China.

Tel: +(86) 0755-82591330 | E-mail: webmaster@lcs-cert.com | Web: www.lcs-cert.com.

Scan code to check authenticity.



2	Conducted Susceptibility Generator	HTEC	CDG6000	126A140012016	2023-04-26	2024-04-25
3	CDN	HTEC	CDN-M2+M3	A22/0382/2016	2023-04-26	2024-04-25
4	6dB attenuator	HTEC	ATT6	HA1601	2023-04-26	2024-04-25
5	Electromagnetic clamp	LUTHI	EM101	35535	2023-04-26	2024-04-25

POWER FREQUENCY MAGNETIC FIELD

Item	Test equipment	Manufacturer	Model No.	Serial No.	Cal Date	Due Date
1	Power Frequency Mag-Field Generator System	HTEC	HPFMF100	100-2400	2023-04-26	2024-04-25

RADIO-FREQUENCY ELECTROMAGNETIC FIELDS

Item	Test equipment	Manufacturer	Model No.	Serial No.	Cal Date	Due Date
1	3m Semi Anechoic Chamber	SIDT FRANKONIA	SAC-3M	03CH03-HY	2023-03-02	2026-03-01
2	RF signal generator	Agilent	8648B	3847M00804	2023-03-02	2024-03-01
3	Power amplifier	SKET	LPA 0810-150	202302457	2023-03-02	2024-03-01
4	Field generating antenna	SKET	STLP 9129 Plus	/	/	/
5	Power probe	R&S	NRP-Z11	115232	2023-03-02	2024-03-01
6	Power probe	R&S	NRP-Z11	117755	2023-03-02	2024-03-01
7	Test Software	SKET	EMC-S	N/A	/	/





4. VERDICT SUMMARY SECTION

This chapter present an overview of the standards and results. Refer the next chapter for details of measured test results and applied test levels.

4.1. STANDARD(S)

EN IEC 55015:2019+A11:2020 - Limits and methods of measurement of radio disturbance characteristics of electrical lighting and similar equipment.

EN IEC 61547:2023 - Equipment for general lighting purposes — EMC immunity requirements.





4.2. OVERVIEW OF RESULTS

EMISSION TESTS - EN IEC 55015		
Requirement - Test case	Limit	Verdict
Conducted Disturbance - electric power supply	Table 1, Table 4	N/A
Conducted Disturbance - wired network ports at other than power supply	Table 2, Table 3	N/A
Conducted Disturbance - local wired ports at other than electrical power supply interface of ELV lamp	Table 5, Table 6	PASS
Assessment of the enclosure port	---	---
Radiated Disturbance in the frequency range 9 kHz to 30 MHz	Table 8, Table 9	PASS
Radiated Disturbance in the frequency range 30 MHz to 1 GHz	Table 10	PASS
IMMUNITY TESTS - EN IEC 61547		
Requirement - Test case	Basic Standard(s)	Verdict
Electrostatic Discharge	IEC/EN 61000-4-2	PASS
Radio-Frequency Electromagnetic Fields	IEC/EN 61000-4-3	PASS
Electrical Fast Transient / Burst	IEC/EN 61000-4-4	PASS
Surge	IEC/EN 61000-4-5	N/A
Injected Currents (Radio-Frequency Common Mode)	IEC/EN 61000-4-6	PASS
Power Frequency Magnetic Field ¹	IEC/EN 61000-4-8	N/A
Voltage Dips and Short Interruptions	IEC/EN 61000-4-11	N/A

Supplementary information:

1) Only need to be applied to equipment containing components susceptible to magnetic fields.



Shenzhen Southern LCS Compliance Testing Laboratory Ltd.

101-201, No. 39 Building, Xialang Industrial Zone, Heshuikou Community, Matian Street, Guangming District, Shenzhen, China.

Tel: +(86) 0755-82591330 | E-mail: webmaster@lcs-cert.com | Web: www.lcs-cert.com.

Scan code to check authenticity.



5. EMISSION TESTS

5.1. CONDUCTED DISTURBANCE

Standard	EN IEC 55015:2019+A11:2020
Basic Standard(s)	CISPR 16-2-1

Disturbance voltage limits at the electric power supply interface

Frequency range [MHz]	Limit: Quasi-peak [dB(μV)]	Limit: Average[dB(μV)]	IF BW
0,009 - 0,05	110	N/A	200 Hz
0,05 - 0,15	90 - 80	N/A	200 Hz
0,15 - 0,5	66 - 56	56 - 46	9 kHz
0,5 - 5,0	56	46	9 kHz
5,0 - 30	60	50	9 kHz

- 1) At the transition frequency, the lower limit applies.
- 2) The limit decreases linearly with the logarithm of the frequency in the ranges 50 kHz to 150 kHz and 150 kHz to 0,5 MHz.
- 3) If the EUT is non-restricted ELV lamps, the limits add 26dB.

Disturbance voltage limits at wired network interfaces other than power supply

Frequency range [MHz]	Limit: Quasi-peak [dB(μV)]	Limit: Average[dB(μV)]	IF BW
0,15 - 5,0	84 - 74	74 - 64	9 kHz
5,0 - 30	74	64	9 kHz

- 1) The limits decrease linearly with the logarithm of the frequency in the range 0.15 MHz to 0.5 MHz.
- 2) The disturbance voltage limits are derived for use with an artificial asymmetrical network (AAN) which presents a common mode (asymmetric mode) impedance of 150 Ω to the measured interface.

Disturbance current limits at wired network interfaces other than power supply

Frequency range [MHz]	Limit: Quasi-peak [dB(μA)]	Limit: Average[dB(μA)]	IF BW
0,15 - 5,0	40 - 30	30 - 20	9 kHz
5,0 - 30	30	20	9 kHz

- 1) The limits decrease linearly with the logarithm of the frequency in the range 0.15MHz to 0.5 MHz.

Disturbance voltage limits at local wired ports: local wired ports other than electrical power supply interface of ELV lamp

Frequency range [MHz]	Limit: Quasi-peak [dB(μV)]	Limit: Average[dB(μV)]	IF BW
0,15 - 5,0	80	70	9 kHz
5,0 - 30	74	64	9 kHz

- 1) At the transition frequency, the lower limit applies.



Test configuration

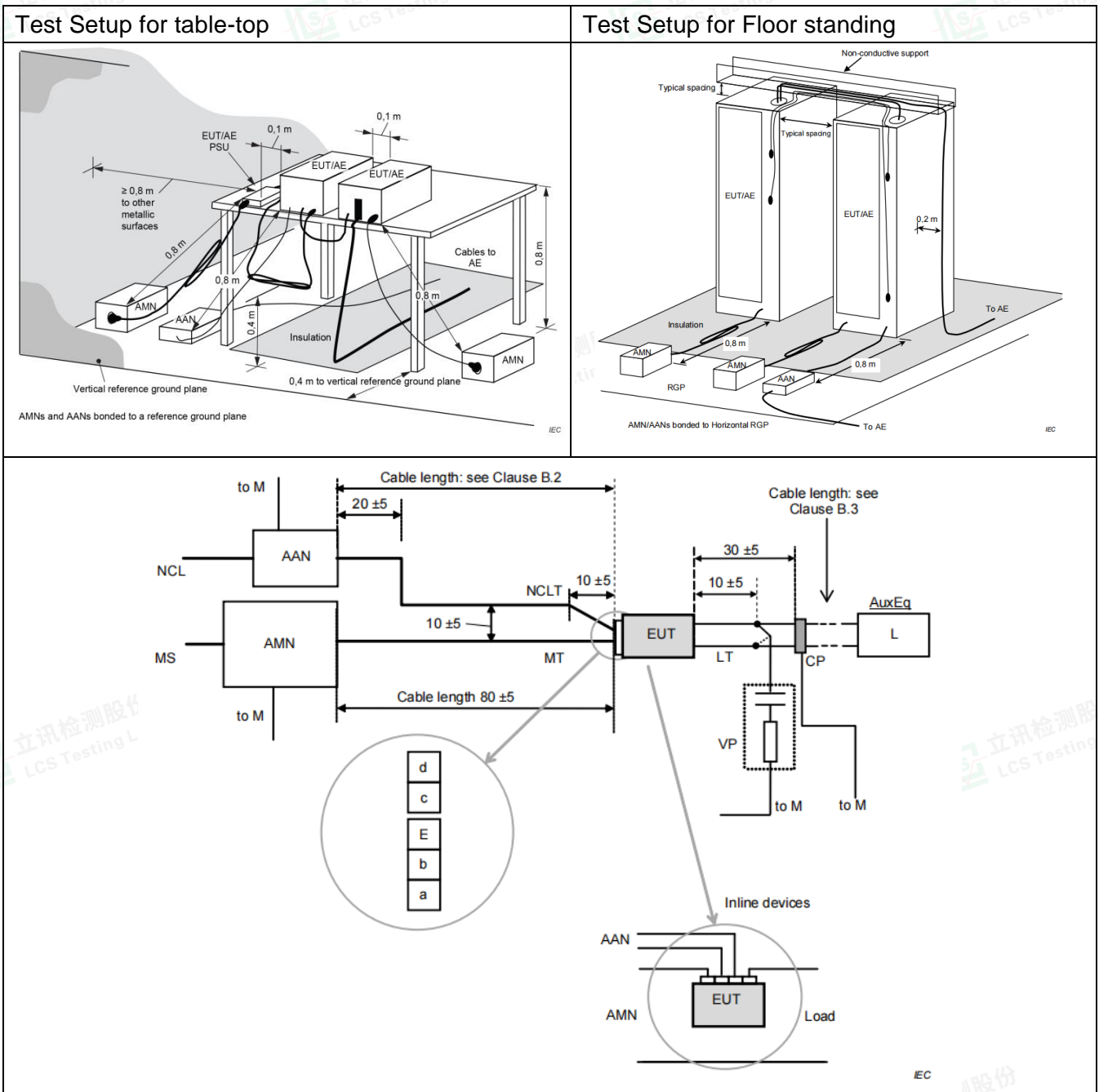

Test Procedure Description

For Table-top, EUT shall be placed at $(0,8 \pm 0,05)$ m above the reference plane of the test site selected for measurement. for Floor standing, EUT shall be placed at $(0,12 \pm 0,04)$ m above the reference plane of the test site selected for measurement. and connected to the AC mains through artificial mains network (LISN). EUT is powered by V-type artificial power network, and the distance from LISN or ANN is 0,8m. the part of the EUT power cord exceeding 0,8m folds in parallel to form a 0,3-0,4 m eights harness.

Test Results refer to Annex A.1



5.2. RADIATED DISTURBANCE (9KHz - 30MHz)

Standard	EN IEC 55015:2019+A11:2020
Basic Standard(s)	CISPR 16-2-3
Test method	Large Loop Antenna (LLA)

LLAS Radiated disturbance limits (2m)

Frequency range [MHz]	Limit: Quasi-peak [dB(μA)]	IF BW
0,009 - 0,07	88	200 Hz
0,07 - 0,15	88 - 58	200 Hz
0,15 - 3,0	58 - 22	9 kHz
3,0 - 30	22	9 kHz

1) At the transition frequency the lower limit applies.
2) Decreasing linearly with logarithm of the frequency.

Test configuration

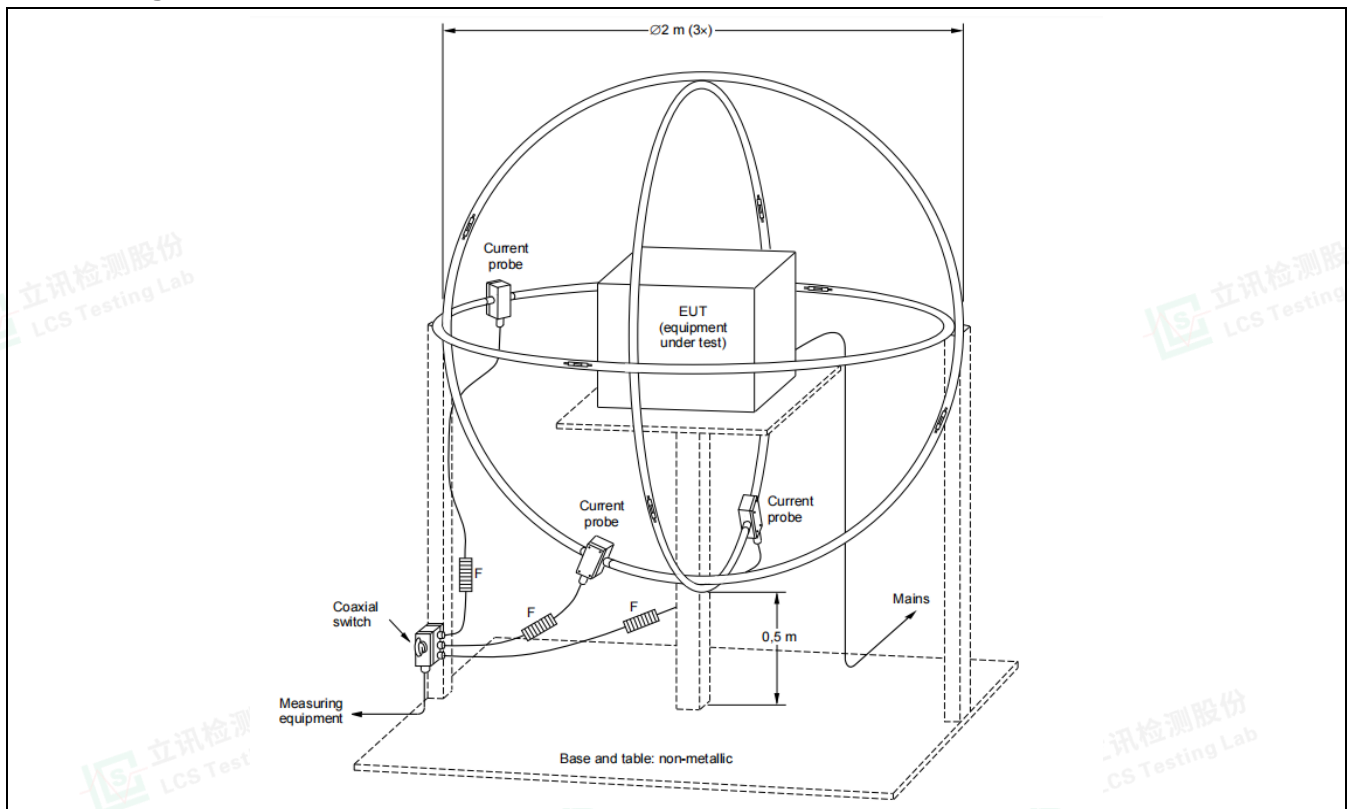

Test Procedure Description

The EUT is placed on a wood table in the center of a loop antenna. the induced current in the loop antenna is measured by means of a current probe and the test receiver. Three field components are checked by means of a coaxial switch.

Test Results refer to Annex A.2



5.3. RADIATED DISTURBANCE (30MHz - 1GHz)

Standard	EN IEC 55015:2019+A11:2020
Basic Standard(s)	CISPR 16-2-3
Test method	Semi Anechoic Chamber (SAC)

SAC Radiated disturbance limit

Frequency range [MHz]	Limit: Quasi-peak [dB(μV/m)]		IF BW
	3 m distance	10 m distance	
30 - 230	40	30	120 KHz
230 - 1000	47	37	120 KHz

- 1) At the transition frequency, the lower limit applies.
- 2) Distance refers to the distance in meters between the measuring instrument antenna geometric center and the closed point of any part of the EUT.

Test configuration

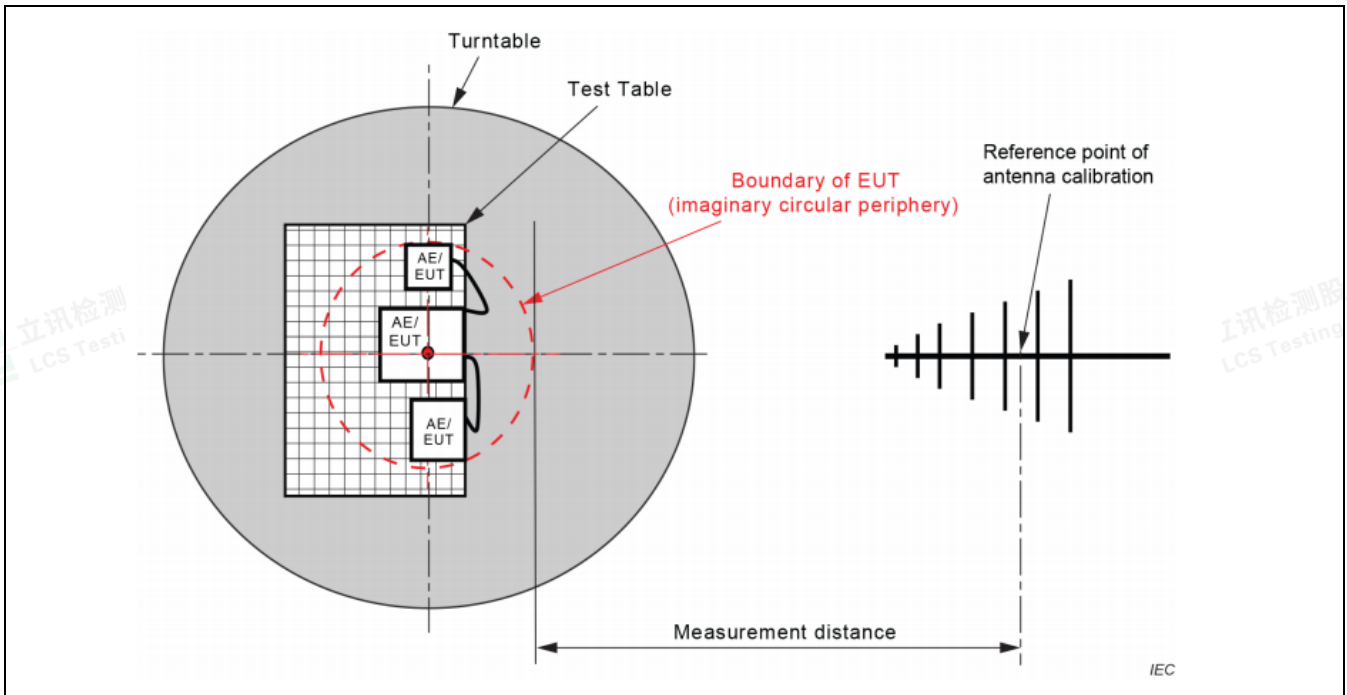

Test Procedure Description

The radiated disturbance test was conducted in a 3m Semi Anechoic Chamber and conforming to CISPR 16-2-3. The EUT is placed on a turntable, which is 0.8 meter high above the ground. The turntable can rotate 360 degrees to determine the position of the maximum emission level. The EUT is set 3 meters away from the receiving antenna, which is mounted on an antenna tower. The antenna can be moved up and down from 1 to 4 meters to find out the maximum emission level. Log-periodic Antenna (calibrated by Dipole antenna) is used as a receiving antenna. Both horizontal and vertical polarization of the antenna is set on test.

Test Results refer to Annex A.3





6. IMMUNITY TESTS

6.1. PERFORMANCE CRITERIA

Standard	EN IEC 61547:2023
----------	-------------------

For the various immunity tests that apply, the performance of the following functions shall be assessed, as far as applicable or specified by the manufacturer:

- the luminous intensity of the luminaire or of the light source(s);
- the control function, for example on/off switching, light level setting, colour adjustment, wireless control.

Performance criterion A: during the test, no change of the luminous intensity shall be observed and the regulating control, if any, shall operate during the test as intended.

Performance criterion B: during the test, the luminous intensity may change to any value. after the test, the luminous intensity shall be restored to its initial value within 1 min(30 min for high pressure gas discharge lamps) regulating controls need not function during the test, but after the test, the mode of the control shall be the same as before the test provided that during the test no mode changing commands were given.

Performance criterion C: during and after the test, any change of the luminous intensity is allowed and the lamp(s) may be extinguished. after the test, within 30 min, all functions shall return to normal, if necessary by temporary interruption of the mains supply and / or operating the regulating control.

Electronic lighting equipment		Tests and performance criteria							
		5.2 (ESD)	5.3 (RS)	5.4 (PFMF)	5.5 (EFT)	5.6 (CS)	5.7 (Surge)	5.8 (Dips)	5.8 (Interruption)
<input type="checkbox"/>	Self-ballasted lamps	B	A	A	B	A	C	B	B
<input checked="" type="checkbox"/>	Lighting equipment (excluding self-ballasted lamps) Module in host	B	A	A	B	A	C	B	B ¹
<input type="checkbox"/>	Luminaire for emergency lighting	B ²	A	A	B ²	A	B ²	See ³	See ³

Supplementary information:

- 1) For ballasts where the lamp is not able to restart within 1 min, due to the physical constraints of the lamp, performance criterion C applies.
- 2) Luminaires for emergency lighting shall be tested in both the normal and emergency mode of operation.
- 3) These tests do not apply as they are covered by the test in IEC 60598-2-22.
- 4) For emergency luminaires designed to operate in high-risk task areas, after the test, the luminous intensity shall be restored to its initial value within 0,5 s.



6.2. ELECTROSTATIC DISCHARGE

Electrostatic discharge (ESD) is the result of accumulated static electricity from a person or object, for example, walking on a synthetic carpet. ESD can indirectly affect the operation of equipment or damage its electronic components through direct discharge or coupling. both effects were simulated during the test. contact discharge is the preferred test method. twenty discharges (10 with positive and 10 with negative polarity) shall be applied on each accessible metallic part of the enclosure (terminals are excluded). air discharges shall be used where contact discharges cannot be applied. discharges shall be applied on the horizontal or vertical coupling planes.

Requirements

Standard	EN IEC 61547:2023							
Basic standard	EN 61000-4-2							
Port under test	Enclosure							
Contact discharge	<input checked="" type="checkbox"/>	± 2 kV	<input checked="" type="checkbox"/>	± 4 kV	<input type="checkbox"/>	±8 kV	<input type="checkbox"/>	±15 kV
Air discharge	<input checked="" type="checkbox"/>	± 2 kV	<input checked="" type="checkbox"/>	± 4 kV	<input checked="" type="checkbox"/>	±8 kV	<input type="checkbox"/>	±15 kV
Number of discharges	≥ 10 per polarity with ≥ 1 sec interval							
Note : Road and street lighting equipment shall be tested for air discharge at ±15 kV and for contact discharge at ±8 kV. This is to simulate the phenomenon of static charging during thunderstorms.								

Test configuration

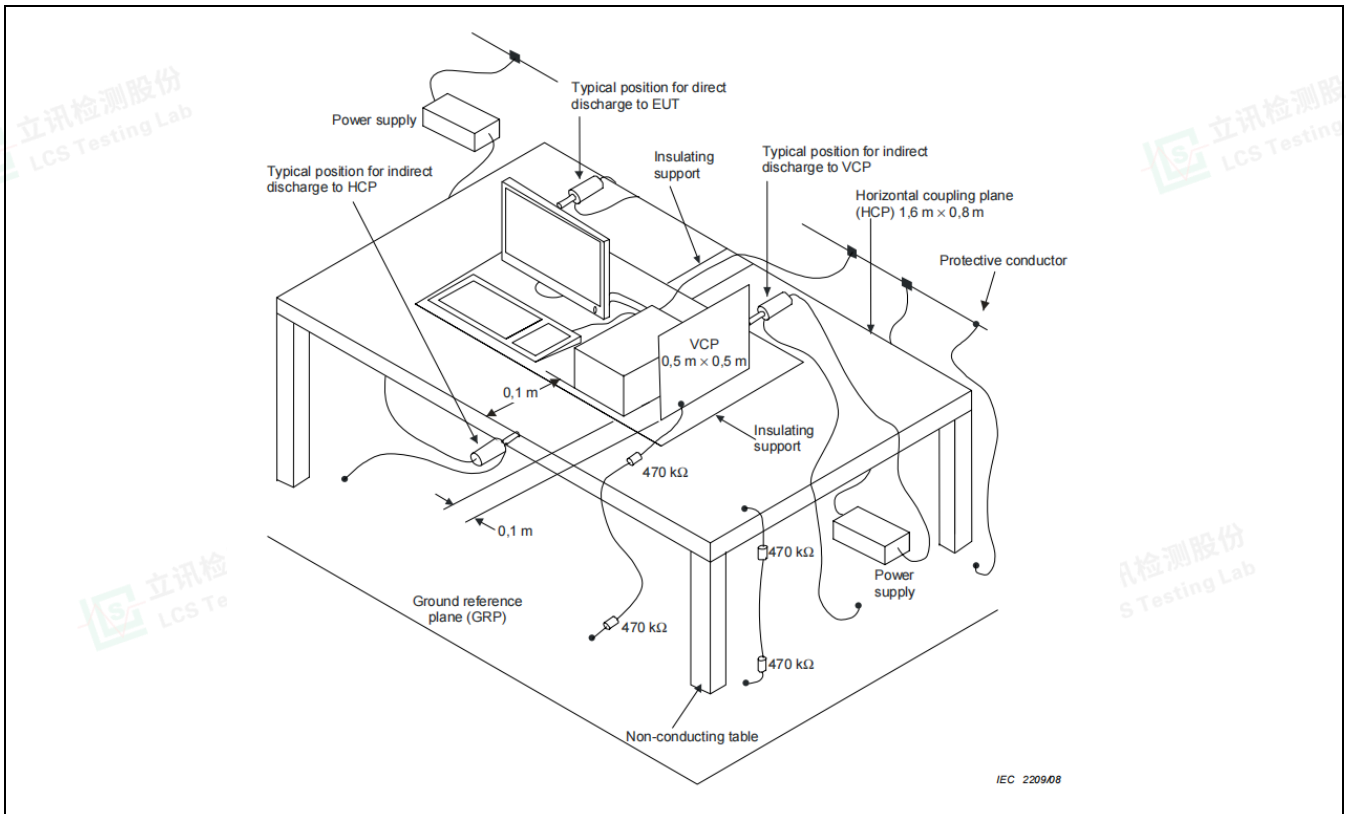

Test Results refer to Annex A.4



6.3. RADIO-FREQUENCY ELECTROMAGNETIC FIELDS

During the test it is verified if the EUT has sufficient immunity against radiated electromagnetic fields. The test was carried out in a half-wave anechoic chamber with absorbent material attached to a reflective ground plane. Before the test, the test field strength needs to be calibrated. during the calibration, the corresponding relationship between the target field strength and the forward power applied to the transmitting antenna is established. during the test, except for EUT, the indoor layout is consistent with the calibration.

The EUT and its simulators are placed on a turn table which is 0,8 meter above ground. EUT is set 3 meter away from the transmitting antenna which is mounted on an antenna tower. both horizontal and vertical polarization of the antenna are set on test. each of the four sides of EUT must be faced this transmitting antenna and measured individually. in order to judge the EUT performance, a CCD camera is used to monitor EUT screen.

Requirements

Standard	EN IEC 61547:2023			
Basic standard	EN 61000-4-3			
Port under test	Enclosure			
Frequency range	Test level	Modulation	Dwell time	Step size
80 - 1000 MHz	3 V/m	1 kHz, 80 % AM	≥ 0,5 s	≤ 1%

Test configuration

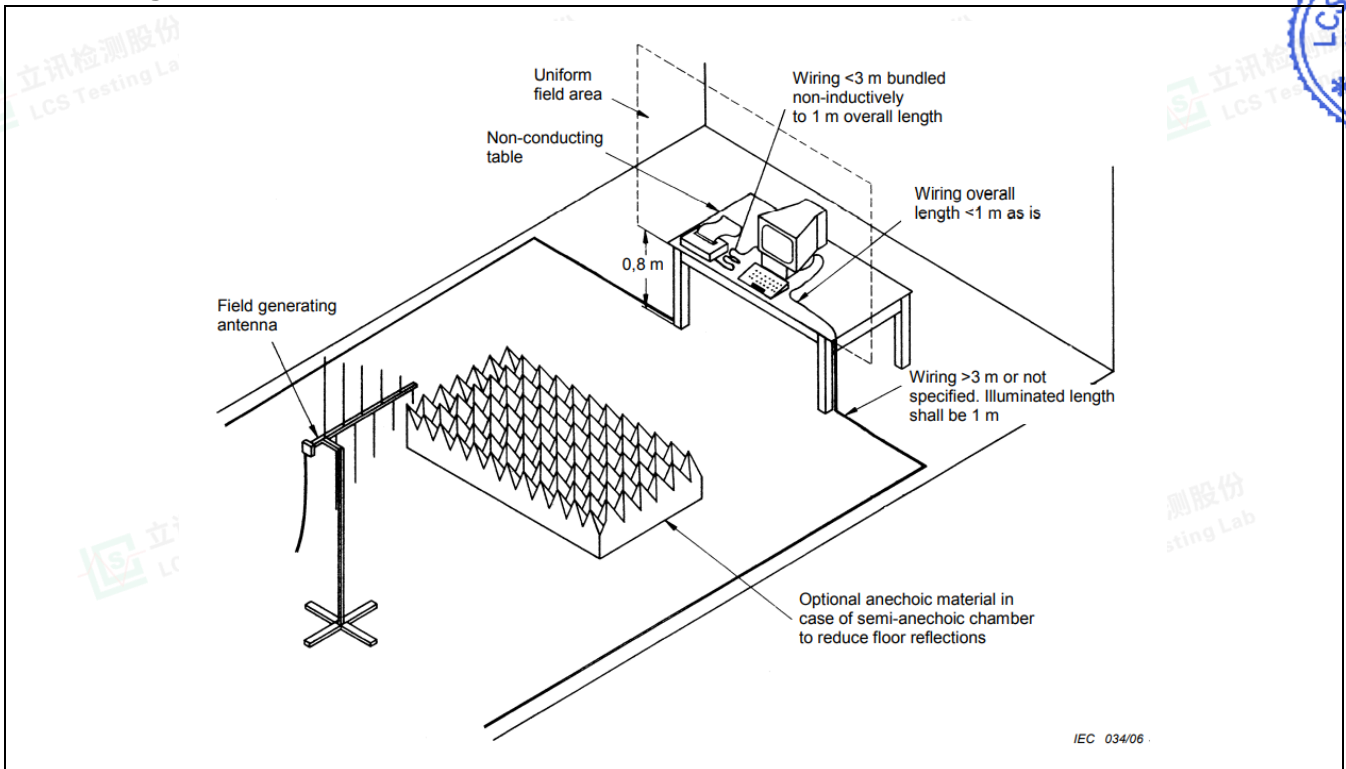

Test Results refer to Annex A.4



6.4. ELECTRICAL FAST TRANSIENT / BURST

The EFT immunity test simulates the disturbances by caused of very short transient bursts.

The EUT is put on the Insulating support which is 0.1 meter high above the ground reference plane. the minimum distance between EUT and all other conductive structure, except the ground plane beneath the EUT, shall be more than 0.5 m. both polarities of the test voltage should be applied during test, fast transients are carried out with a minimum duration of 2 min with a positive polarity and a minimum of 2 min with a negative polarity.

Requirements

Standard		EN IEC 61547:2023		
Basic standard		EN 61000-4-4		
Pulse characteristics		5/50 ns		
Port under test		Test level	Repetition frequency	Duration
<input type="checkbox"/>	AC input / output power	± 1000 V	5 kHz	2 min / polarity
<input checked="" type="checkbox"/>	DC input / output power ²	± 500 V	5 kHz	2 min / polarity
<input type="checkbox"/>	Signal / control lines and load ¹ ports	± 500 V	5 kHz	2 min / polarity

- 1) Only applicable to ports interfacing with cables whose whose total length may exceed 3 m.
- 2) Not applicable to equipment not connected to the mains while in use.

Test configuration

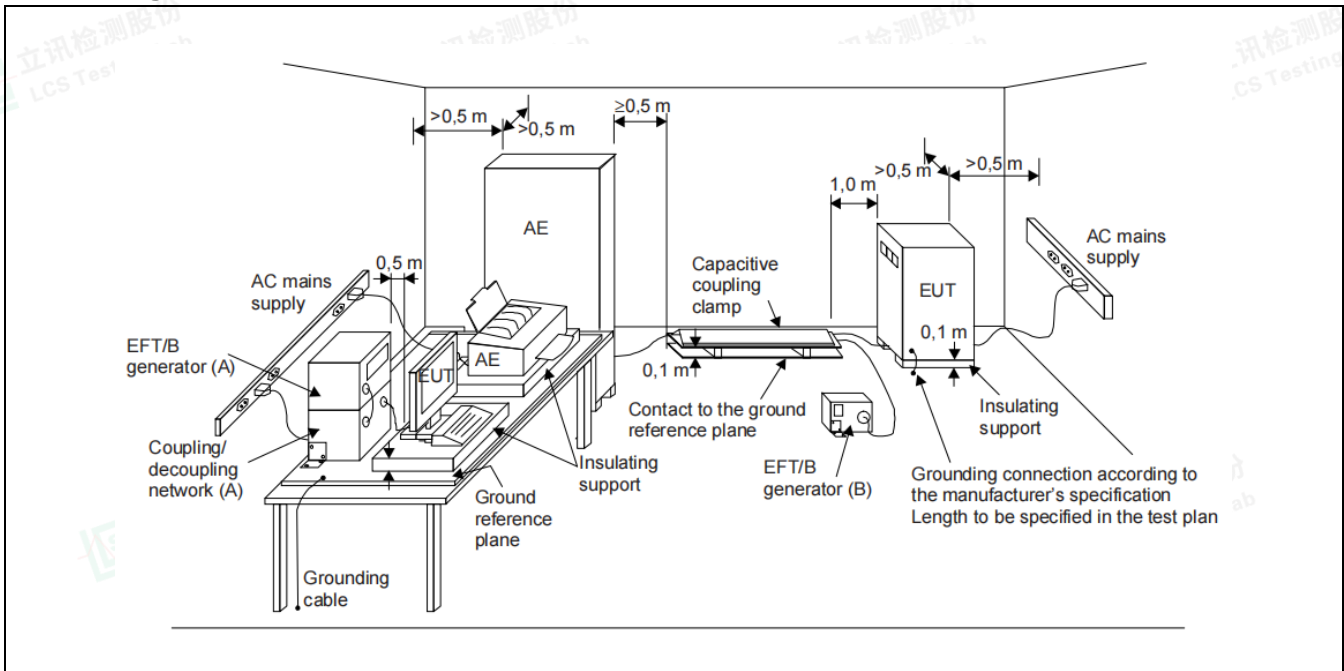

Test Results refer to Annex A.4



6.5. INJECTED CURRENTS (RADIO-FREQUENCY COMMON MODE)

During the test the immunity of the EUT for conducted electromagnetic fields is checked .

The equipment to be tested is placed on an insulating support of $0,1\text{ m} \pm 0,05\text{ m}$ height above a reference ground plane. a non conductive roller / caster in the range of $0,1\text{ m} \pm 0,05\text{ m}$ above the reference ground plane can be used as an alternative to an insulating support. all cables exiting the EUT shall be supported at a height of at least 30 mm above the reference ground plane. The coupling and decoupling devices shall be placed on the reference ground plane, making direct contact with it at a distance of 0,1 m to 0,3 m from the EUT.

Requirements

Standard	EN IEC 61547:2023				
Basic standard	EN 61000-4-6				
Frequency range	0,15 - 80 MHz				
Port under test	Test level	Modulation	Dwell time	Step size	
<input type="checkbox"/> AC input / output power	3 V	1 kHz, 80 % AM	$\geq 0,5\text{ s}$	$\leq 1\%$	
<input checked="" type="checkbox"/> DC input / output power ^{1 2}	3 V	1 kHz, 80 % AM	$\geq 0,5\text{ s}$	$\leq 1\%$	
<input type="checkbox"/> Signal / control line ²	3 V	1 kHz, 80 % AM	$\geq 0,5\text{ s}$	$\leq 1\%$	
1) Not applicable to equipment not connected to the mains while in use. 2) Only applicable to ports interfacing with cables whose whose total length may exceed 3 m.					

Test configuration

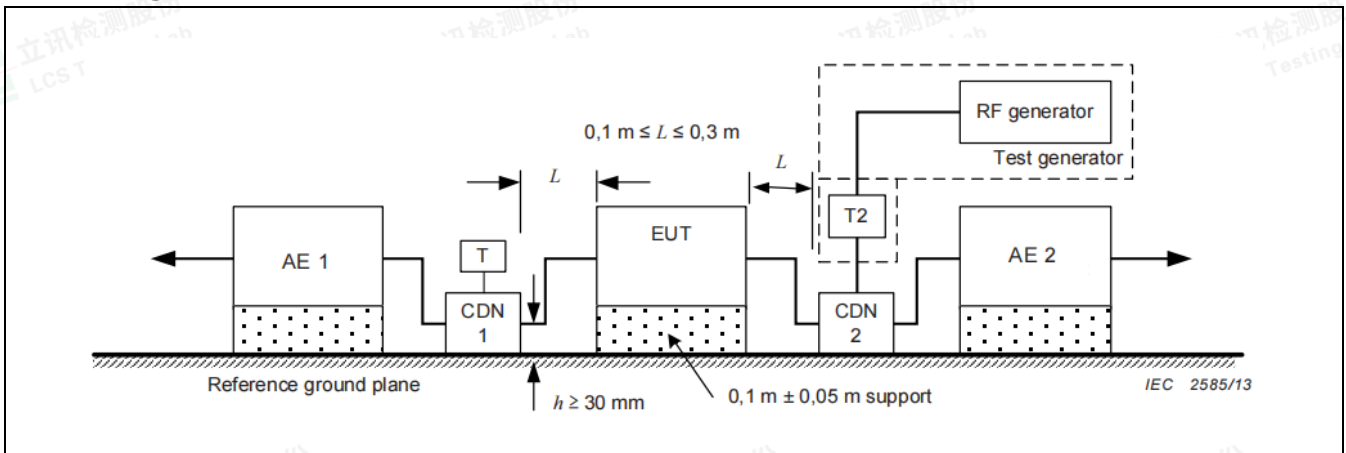

Test Results refer to Annex A.4





ANNEX A - TEST RESULTS

A.1. CONDUCTED DISTURBANCE TEST RESULTS

Environmental Conditions	24.3°C, 51% RH
Model	OLL7-2000-1
Operating mode	Mode 1 (worst case)
Test voltage	DC24V
Test engineer	Peng Dong
Pol	+

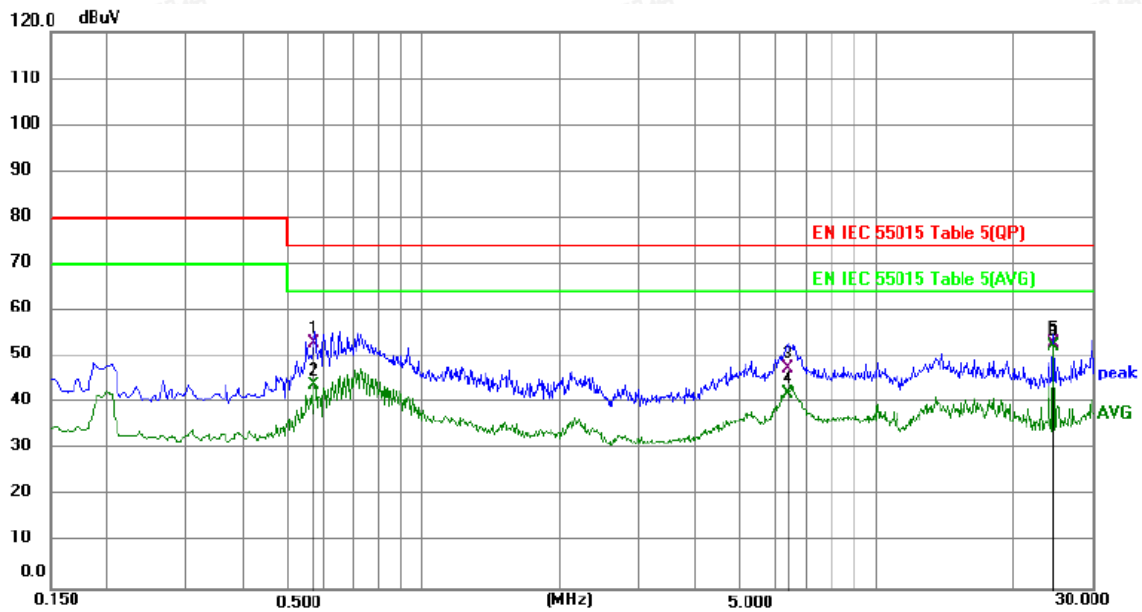

No.	Mk.	Freq. MHz	Reading Level dBuV	Correct Factor dB	Measure- ment dBuV	Limit dBuV	Over dB	Detector	Comment
1		0.5773	6.77	46.06	52.83	74.00	-21.17	QP	
2		0.5773	-2.17	46.06	43.89	64.00	-20.11	AVG	
3		6.3701	1.13	46.28	47.41	74.00	-26.59	QP	
4		6.3701	-4.21	46.28	42.07	64.00	-21.93	AVG	
5		24.5762	5.50	47.42	52.92	74.00	-21.08	QP	
6	*	24.5762	5.06	47.42	52.48	64.00	-11.52	AVG	





Environmental Conditions	24.3°C, 51% RH
Model	OLL7-2000-1
Operating mode	Mode 1 (worst case)
Test voltage	DC24V
Test engineer	Peng Dong
Pol	Neutral

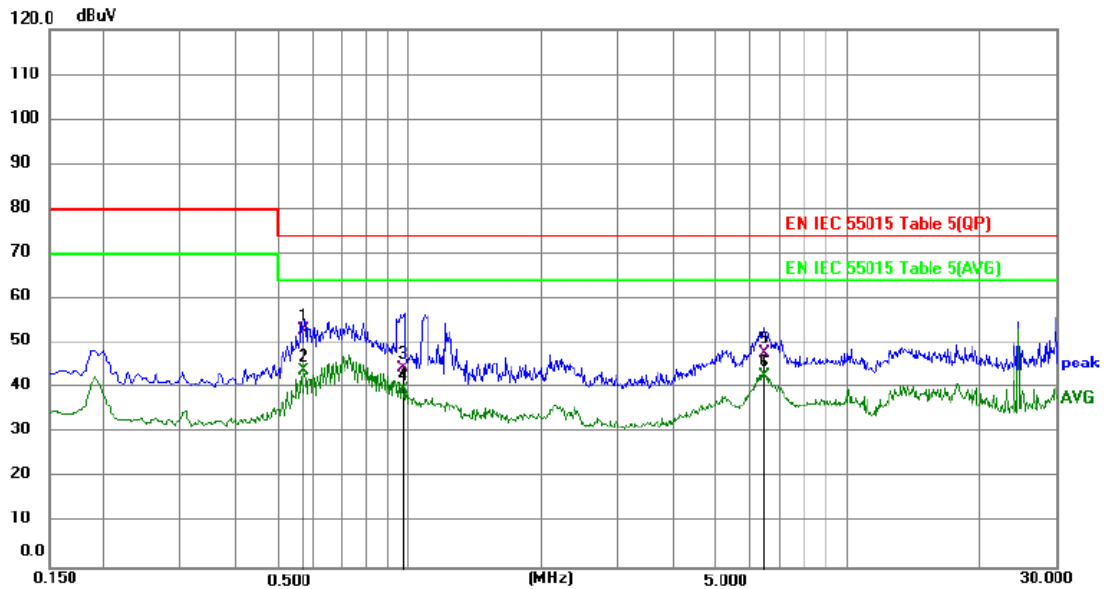

No.	Mk.	Freq. MHz	Reading Level dBuV	Correct Factor dB	Measure- ment dBuV	Limit dBuV	Over dB	Detector	Comment
1		0.5756	6.75	46.06	52.81	74.00	-21.19	QP	
2	*	0.5756	-2.08	46.06	43.98	64.00	-20.02	AVG	
3		0.9714	-1.55	45.99	44.44	74.00	-29.56	QP	
4		0.9714	-6.35	45.99	39.64	64.00	-24.36	AVG	
5		6.4832	1.55	46.30	47.85	74.00	-26.15	QP	
6		6.4832	-3.64	46.30	42.66	64.00	-21.34	AVG	





A.2. RADIATED DISTURBANCE TEST RESULTS (9kHz - 30MHz)

Environmental Conditions	24.3°C, 51% RH
Model	OLL7-2000-1
Operating mode	Mode 1 (worst case)
Test voltage	DC24V
Test engineer	Peng Dong
Pol	X

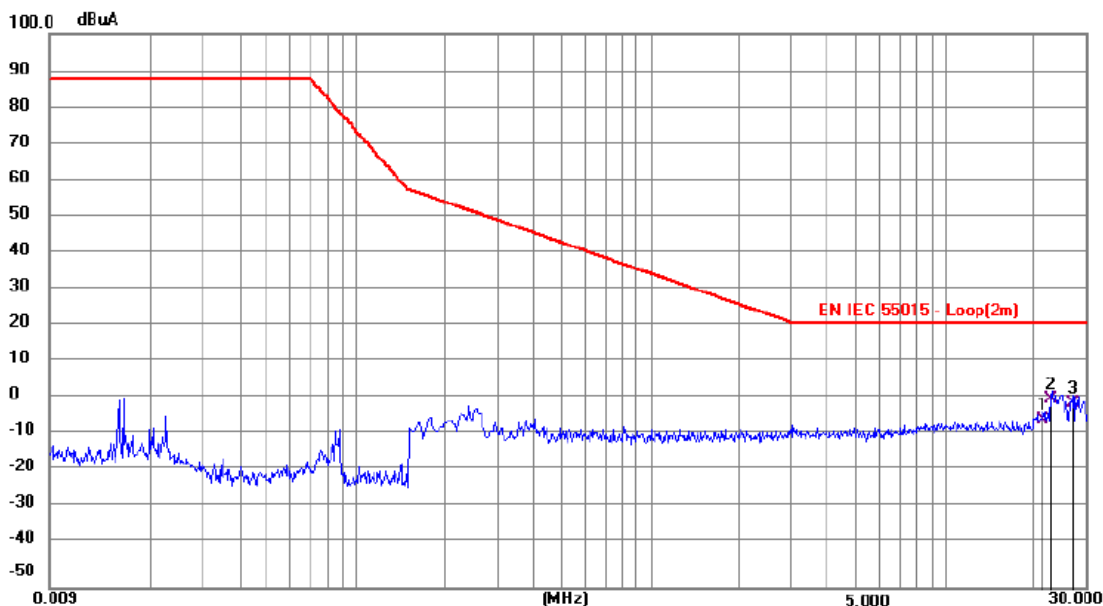

No.	Mk.	Freq. MHz	Reading Level dBuA	Correct Factor dB	Measure- ment dBuA	Limit dBuA	Over dB	Detector	Comment
1		21.4350	-29.23	24.94	-4.29	22.00	-26.29	QP	
2	*	23.0009	-23.38	24.66	1.28	22.00	-20.72	QP	
3		27.0510	-23.76	23.93	0.17	22.00	-21.83	QP	





Environmental Conditions	24.3°C, 51% RH
Model	OLL7-2000-1
Operating mode	Mode 1 (worst case)
Test voltage	DC24V
Test engineer	Peng Dong
Pol	Y

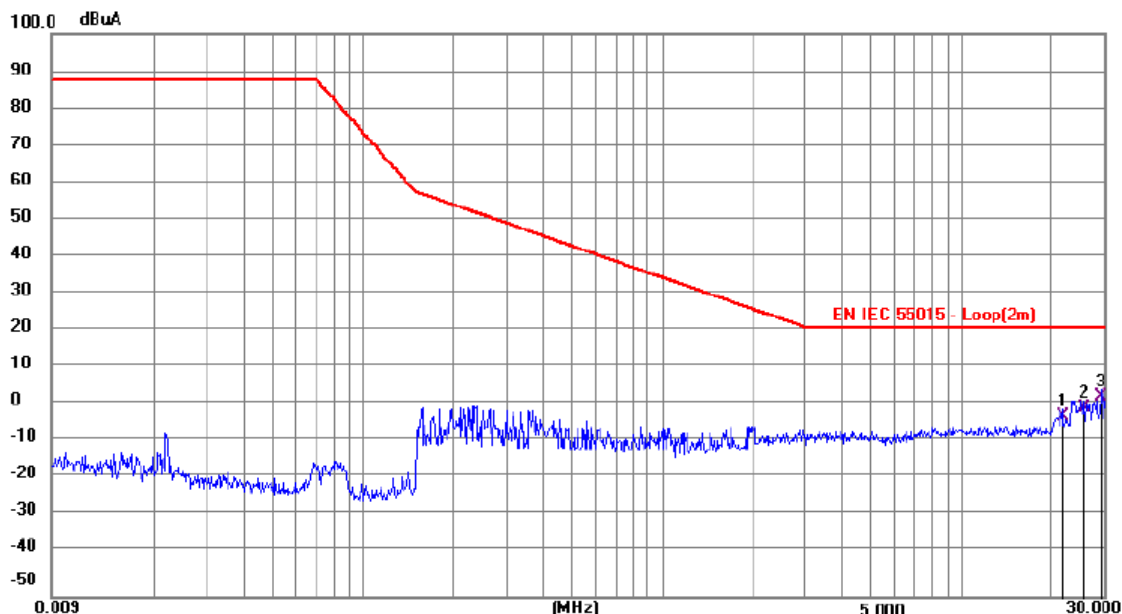

No.	Mk.	Freq. MHz	Reading Level dBuA	Correct Factor dB	Measure- ment dBuA	Limit dBuA	Over dB	Detector	Comment
1		21.8580	-27.13	25.21	-1.92	22.00	-23.92	QP	
2		25.5210	-23.99	24.44	0.45	22.00	-21.55	QP	
3	*	29.3820	-20.37	23.63	3.26	22.00	-18.74	QP	





Environmental Conditions	24.3°C, 51% RH
Model	OLL7-2000-1
Operating mode	Mode 1 (worst case)
Test voltage	DC24V
Test engineer	Peng Dong
Pol	Z

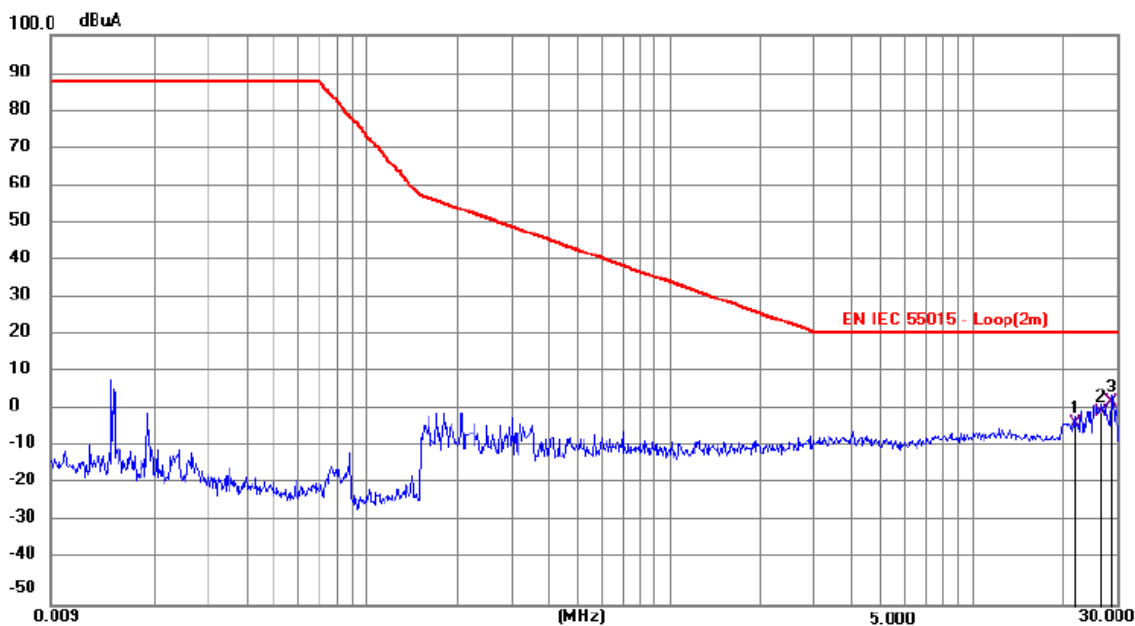

No.	Mk.	Freq. MHz	Reading Level dBuA	Correct Factor dB	Measure- ment dBuA	Limit dBuA	Over dB	Detector	Comment
1		21.8310	-27.66	25.36	-2.30	22.00	-24.30	QP	
2		26.4660	-23.36	24.25	0.89	22.00	-21.11	QP	
3	*	28.7470	-20.32	23.70	3.38	22.00	-18.62	QP	





A.3. RADIATED DISTURBANCE TEST RESULTS (30MHz - 1GHz)

Environmental Conditions	24.4°C, 51% RH
Model	OLL7-2000-1
Operating mode	Mode 1 (worst case)
Test voltage	DC24V
Test engineer	Peng Dong
Pol	Vertical

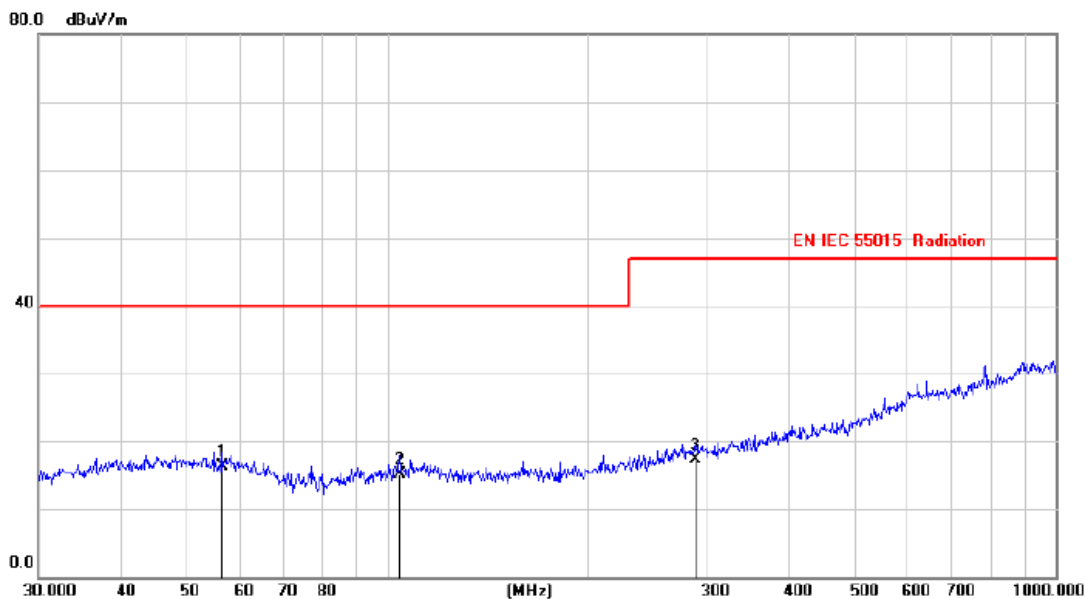

No.	Mk.	Freq. MHz	Reading Level dBuV	Correct Factor dB	Measure- ment dBuV/m	Limit dBuV/m	Margin dB	Antenna Height cm	Table Degree degree	Comment
1	*	56.4938	4.24	12.05	16.29	40.00	-23.71	QP		
2		104.3987	3.14	11.87	15.01	40.00	-24.99	QP		
3		289.1288	3.23	14.02	17.25	47.00	-29.75	QP		





Environmental Conditions	24.4°C, 51% RH
Model	OLL7-2000-1
Operating mode	Mode 1 (worst case)
Test voltage	DC24V
Test engineer	Peng Dong
Pol	Horizontal

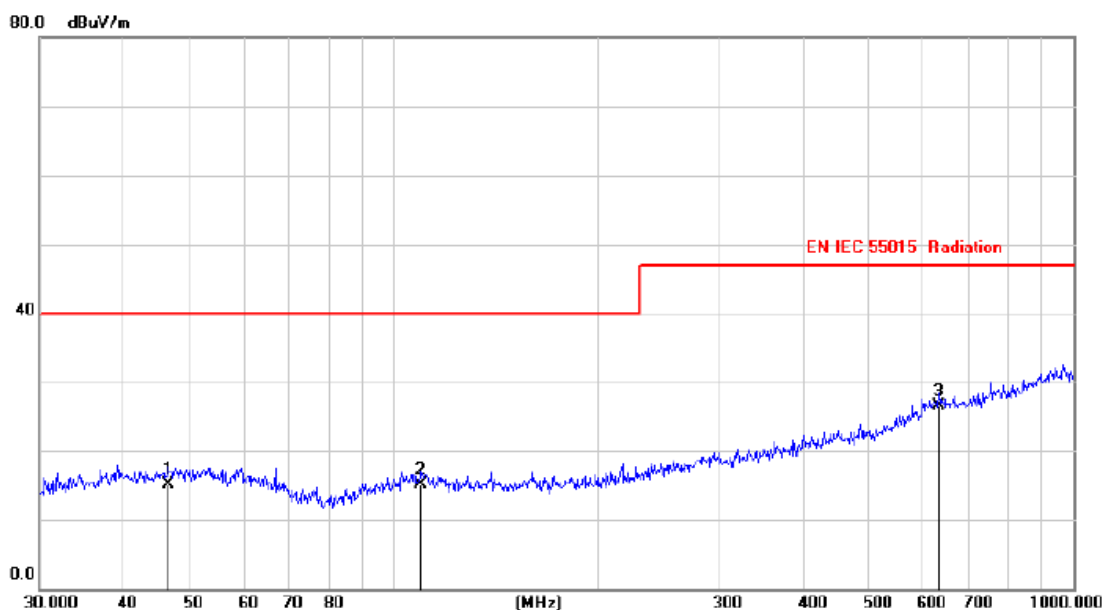

No.	Mk.	Freq. MHz	Reading Level dBuV	Correct Factor dB	Measure- ment dBuV/m	Limit dBuV/m	Margin dB	Antenna Height cm	Table Degree degree	Comment
1		46.4216	2.49	12.59	15.08	40.00	-24.92	QP		
2		109.5076	2.71	12.45	15.16	40.00	-24.84	QP		
3	*	633.9073	5.57	20.95	26.52	47.00	-20.48	QP		



**A.4. IMMUNITY TEST RESULTS**

ELECTROSTATIC DISCHARGE TEST RESULTS					
Test model	OLL7-2000-1		Temperature	23.5°C	
Test mode	Mode 1		Humidity	52%	
Input voltage	DC24V		Pressure	1008mbar	
Test engineer	Peng Dong				
Discharge Mode	Test Points	Test Voltage (kV) & polarity	Number of discharges/polarity	Discharge interval (s)	Performance Criteria
Contact Discharge	Conductive surfaces	± 4	10	1	B
Air Discharge	Insulating surfaces	± 2&4&8	10	1	B
VCP	-	± 4	10	1	B
HCP	-	± 4	10	1	B
Note :					

RADIO-FREQUENCY ELECTROMAGNETIC FIELD TEST RESULTS				
Test model	OLL7-2000-1		Temperature	24.5°C
Test mode	Mode 1		Humidity	53%
Input voltage	DC24V		Pressure	1008mbar
Test engineer	Peng Dong			
Angle of EUT	Antenna polarization	Frequency Range	Test Level	Performance Criteria
0°	Vertical, Horizontal	80 - 1000 MHz	3 V/m	A
90°	Vertical, Horizontal	80 - 1000 MHz	3 V/m	A
180°	Vertical, Horizontal	80 - 1000 MHz	3 V/m	A
270°	Vertical, Horizontal	80 - 1000 MHz	3 V/m	A
Note :				
(1) Modulation:1kHz, 80% AM.				





ELECTRICAL FAST TRANSIENT/BURST TEST RESULTS				
Test model	OLL7-2000-1		Temperature	24.0°C
Test mode	Mode 1		Humidity	54%
Input voltage	DC24V		Pressure	1008mbar
Test engineer	Peng Dong			
Port under test	Test Level&polarity	Repetition Frequency	Test duration /polarity	Performance Criteria
AC input power				
DC input power	± 0.5 kV	5 kHz	2min	B
Signal/control/load				
Note :				

INJECTED CURRENTS (RADIO-FREQUENCY COMMON MODE) TEST RESULTS				
Test model	OLL7-2000-1		Temperature	24.0°C
Test mode	Mode 1		Humidity	54%
Input voltage	DC24V		Pressure	1008mbar
Test engineer	Peng Dong			
Port under test	Test Level	Coupling method	Dwell time	Performance Criteria
AC input power				
DC input power	3 V	CDN	1 seconds	A
Signal/control				
Note: (1) Frequency range:0.15MHz - 80MHz.				



ANNEX B - TEST PHOTOS

B.1. Conducted Disturbance

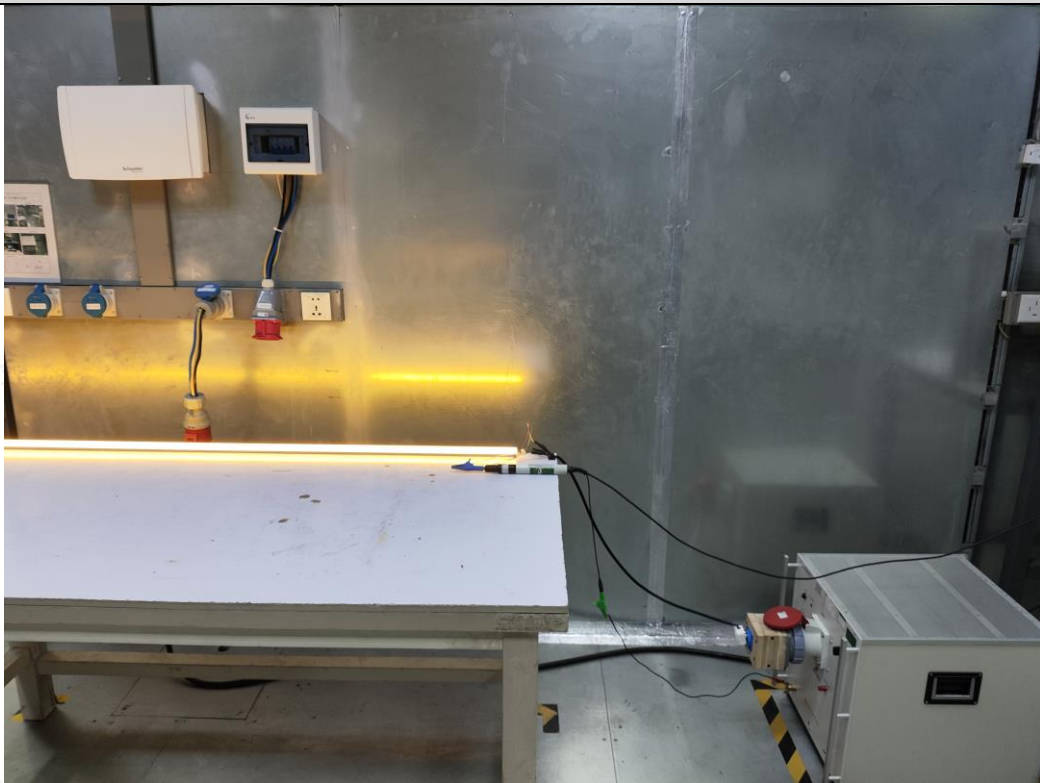

B.2. Radiated Disturbance (9kHz - 30MHz)



B.3. Radiated Disturbance (30MHz to 1GHz) & Radio-Frequency Electromagnetic Fields

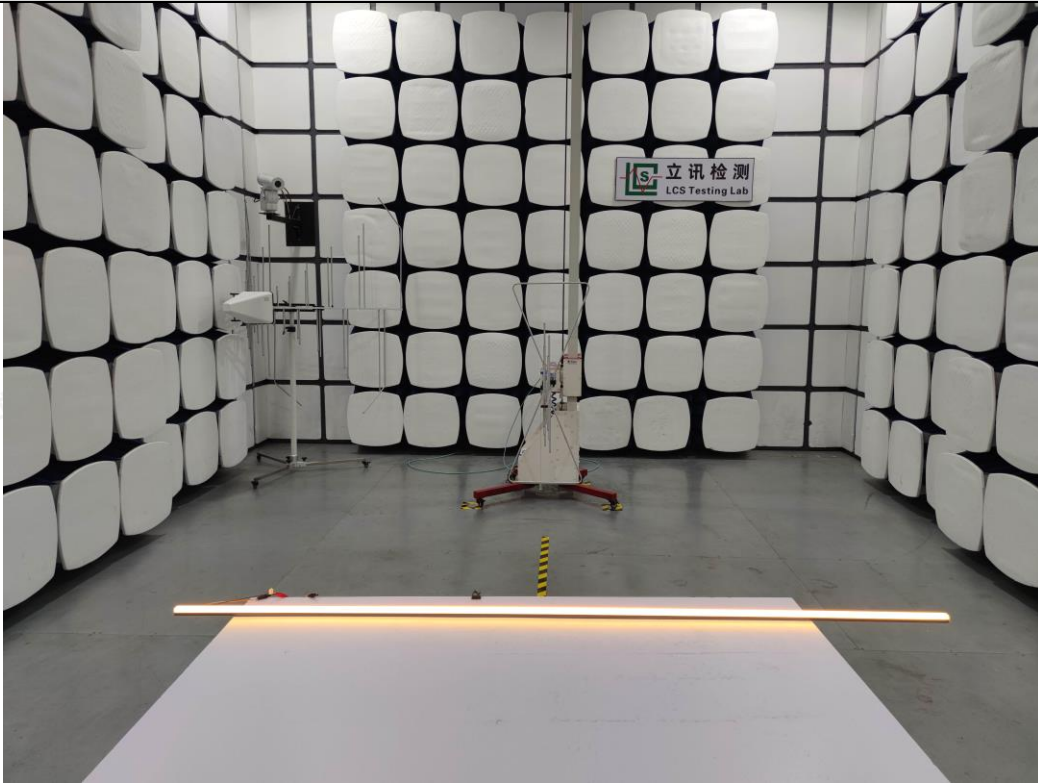

B.4. Electrostatic Discharge



B.5. Electrical Fast Transient / Burst

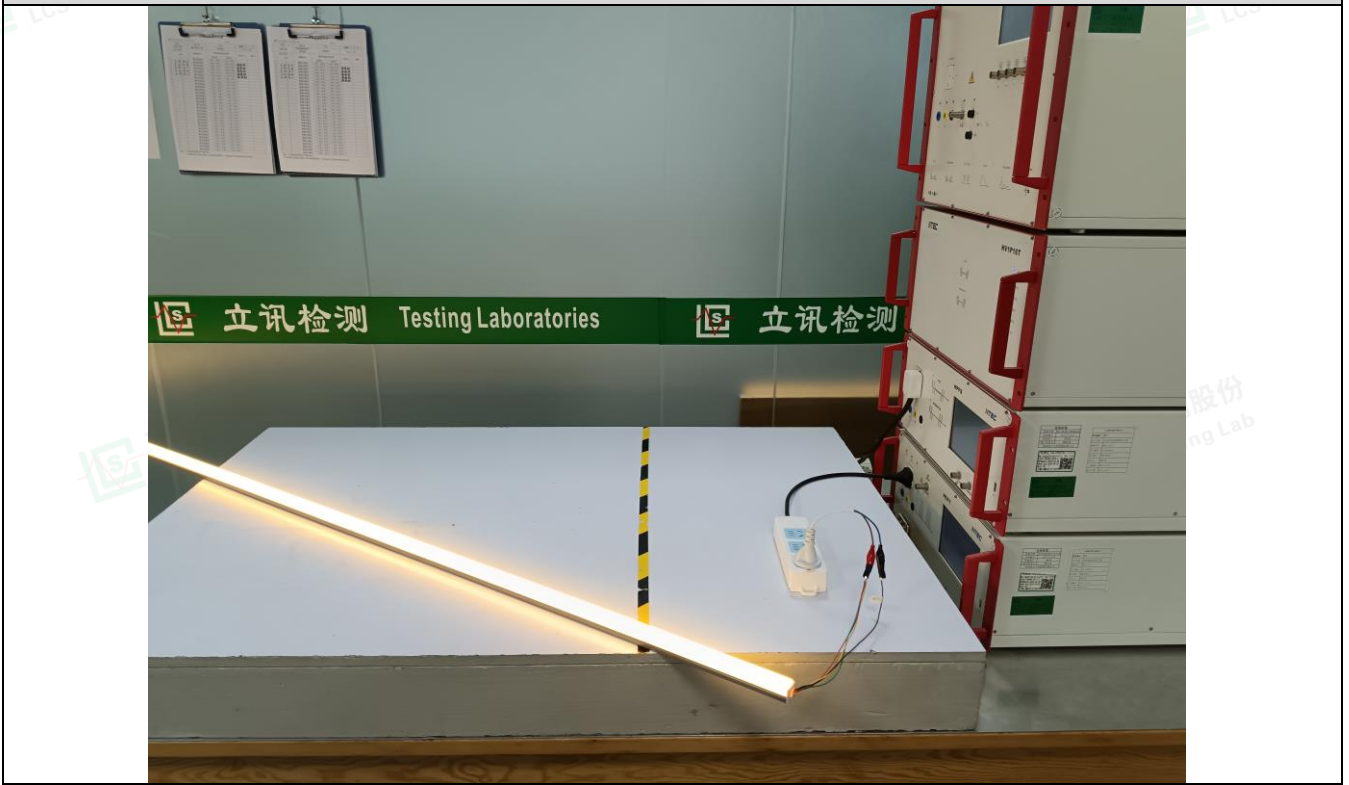

B.6. Injected Currents (Radio-Frequency Common Mode)

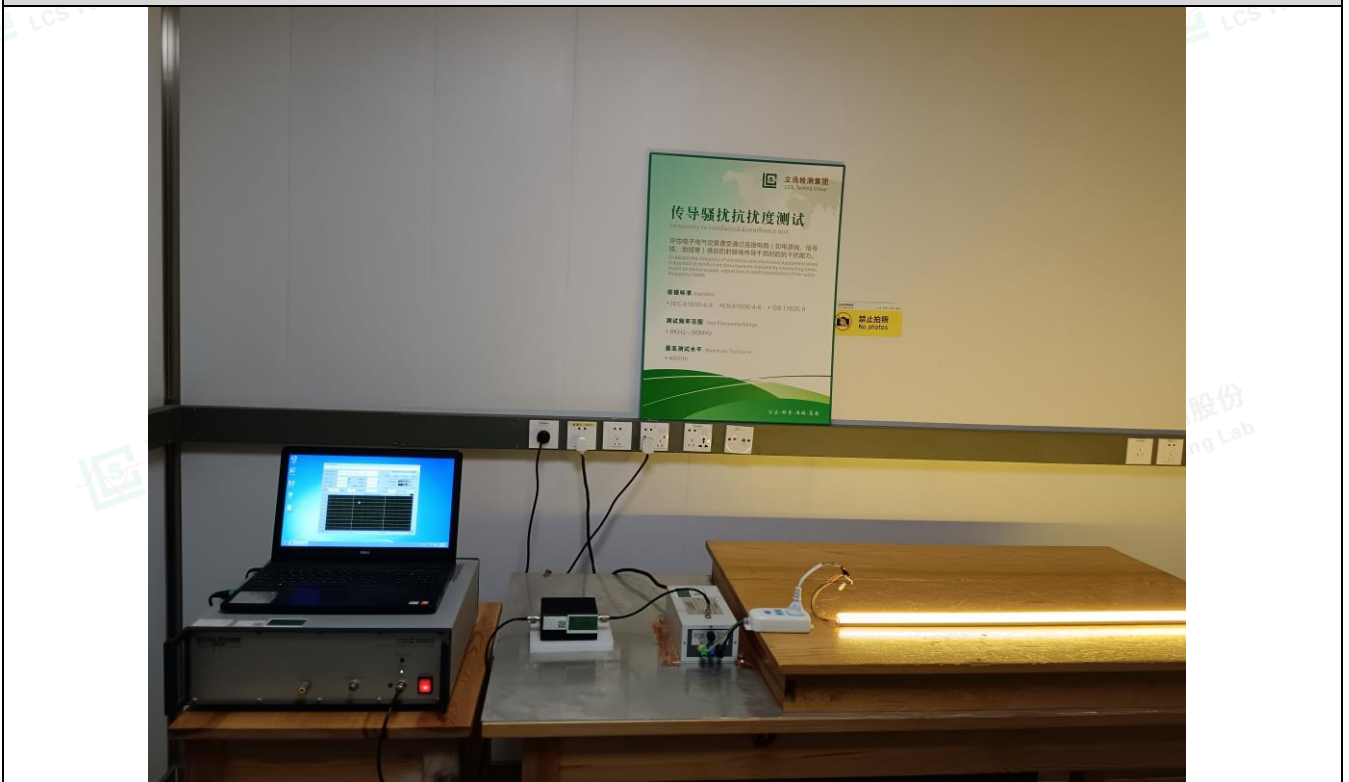



ANNEX C - EXTERNAL AND INTERNAL PHOTOS OF THE EUT



Photo.1



Photo.2



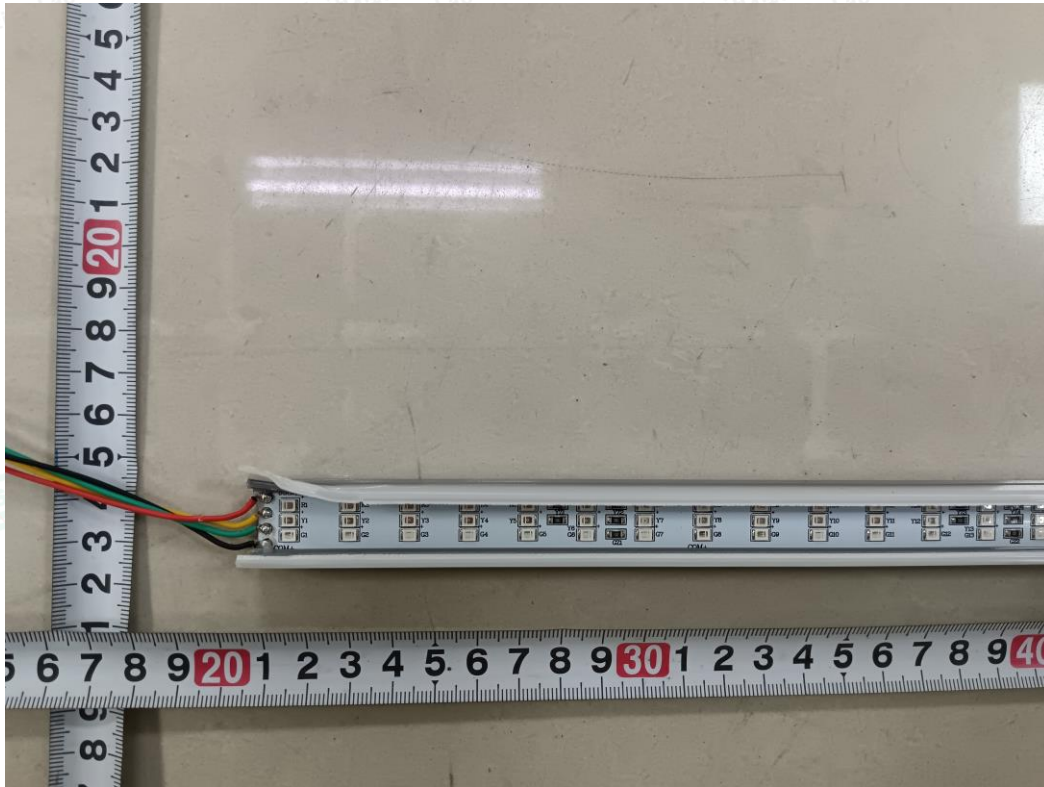

Photo.3

----- END -----

